

AIA BUFFALO EMERGING PROFESSIONALS PRESENTS



THE **ANIMAL HOUSE**  
COMPETITION

**NOV 21 2013 - MAR 21 2014**

[www.aiabep.org/animalhouse](http://www.aiabep.org/animalhouse)

# SPONSORS

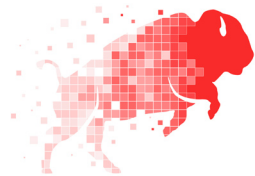

**AIA BEP**  
Buffalo Emerging Professionals

**AMERICAN INSTITUTE OF ARCHITECTS BUFFALO EMERGING PROFESSIONALS**  
Buffalo Emerging Professionals (BEP) is a committee of the American Institute of Architects Buffalo/WNY Chapter whose primary goal is to foster architectural licensure and to support professional development within the design community. The committee endeavors to bridge the gap between young architects, non-licensed professionals, students, and associate members throughout the greater architectural community.

[www.aiabep.org](http://www.aiabep.org)



**AIA Buffalo/WNY**  
A Chapter of the American Institute of Architects

**AMERICAN INSTITUTE OF ARCHITECTS BUFFALO/WNY**  
The American Institute of Architects has been the leading professional membership association for licensed architects, emerging professionals, and allied partners since 1857. The AIA serves as the voice of the architecture profession and the resource for our members in service to society. AIA Buffalo/WNY acts as the organization's vehicle on a local level.

[www.aibuffalowny.org](http://www.aibuffalowny.org)



**BUFFALO ARCHITECTURE FOUNDATION**  
The Buffalo Architecture Foundation (BAF) is a not-for-profit, public charity dedicated to inspiring the exploration and appreciation of architecture and how it shapes our lives. BAF's mission is implemented through educational activities for school-aged children and public awareness events engaging citizens of all ages.

[www.buffaloarchitecture.org](http://www.buffaloarchitecture.org)



**AVALON DOCUMENT SERVICES**  
From annual reports and employee manuals to color posters and project proposals, Avalon has the capability and the knowledge to complete your job accurately and on time. Our large format division provides the highest quality large format prints in color or black & white. We can also mount your prints on foam core for durability and a look that really stands out.

[www.teamavalon.org](http://www.teamavalon.org)



**BUFFALO HUMANE**  
Buffalo Humane is a No Kill animal rescue organization, operating a shelter just outside Buffalo, in Niagara County, in Pendleton, NY. Devoted to animal welfare in the region, Buffalo Humane operates on a 100% volunteer basis with activities that are funded exclusively through fundraising, contributions, and donations.

[www.buffalohumane.org](http://www.buffalohumane.org)

# AIA BEP

## **ABOUT**

Prior to forming the committee in 2011, there was a period of time when programming opportunities for emerging professionals began to slow down and interest in AIA participation began to dwindle.

Founded and Co-Chaired by Michael LaValley, Assoc. AIA, LEED AP and Manuel Rivera, AIA, BEP has developed several programs and permanent resources for Buffalo area emerging professionals to take advantage of as they traverse their unique career paths.

The committee strives to facilitate programming that directly supports three primary aspects of a young designer's career:

1. Professional Development
2. Education
3. Design

While these facets may overlap in many ways, BEP has spent considerable effort to establish and maintain programming that support the unique components associated with each.

## **BEP PROGRAMMING INCLUDES:**

### **ARE STUDY GROUPS**

Our ARE study groups run quarterly to inform ARE candidates about ways in which to take a specific section of the exam. Strategies for how to study are the primary focus of the sessions.

### **LENDING LIBRARY**

The BEP Lending Library was established in order to provide access to study materials to local emerging professionals who could not otherwise afford them on their own. It is comprised of a full set of Kaplan and PPI study materials that can be taken out for two weeks at a time.

### **RESUME & PORTFOLIO WORKSHOPS**

While the primary focus of BEP is licensure, professional development in other ways is also valued highly. The workshops provide emerging professionals access to hiring managers and architects from local firms to critique their in-progress work in terms of what they look for when hiring their own employees.

### **WEBSITE**

The establishment of a formal website ([www.aiabep.org](http://www.aiabep.org)) will act as an information source for local emerging professionals as well as provide a voice for the entire group. Current news, event listings, IDP/ARE information, and descriptions of BEP's subcommittees can be found throughout the site.

### **NETWORKING EVENTS**

BEP has been proud to sponsor several events to engage emerging professionals and connect them with Architects in the region. The primary goals of these events are to raise awareness for what the committee does as well as to connect the often disparate generations of designers together.

### **FUTURE GOALS**

BEP plans to further establish itself as a fundamental entity in the AIA Buffalo/WNY chapter by creating direct mentoring relationships and ties to community service.

If you would like to know more about the committee or have general questions, please follow our website updates and get connected with us through our various social media.

[www.aiabep.org](http://www.aiabep.org)  
[www.facebook.com/aiabep](https://www.facebook.com/aiabep)  
[www.twitter.com/aiabep](https://www.twitter.com/aiabep)

# ANIMAL HOUSE COMPETITION

**AIA BUFFALO EMERGING PROFESSIONALS** proudly presents  
The 2014 Animal House Competition

This is an ideas-based competition in which entrants are asked to design a 'house' for a domestic animal of their choice. The program's intent is for each participant to develop a contemporary shelter design addressing spatial requirements of non-human species in a fresh & appealing way.

Each entry should speak to the requirements of the animal it is being designed for. There are no real limitations on what type of animal this is, except that the animal must be domesticated. It is up to the designer to determine not only what the immediate shelter for the animal is, but also the specific context they choose to design the shelter within. Is the inhabitation designed on an urban rooftop, in a traditional kitchen, in an open backyard, on a desk?

The designer must understand the animal they design around and develop contemporary solutions for its new home. Design forms that break the mold of what society may have previously deemed as 'typical' for such enclosures will be highly valued by the jury. An emphasis on unique fabrication methods or sustainable design may also allow an entry to stand out.

What does the animal require in terms of space? There should be a clear formal design concept that accommodates the chosen animal's spatial requirements for multiple activities as applicable (ie. sleeping, sitting, standing, etc.). How is the scale of an animal's enclosure related or unrelated to that of a human's house?

The 2014 Animal House Competition is meant to provide a vehicle for Emerging Professionals across New York State to develop their voices in a unique and challenging design endeavor.

**Good Luck to All Participants!**

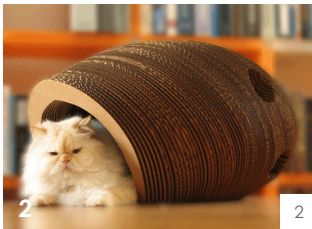

- 1 | Beagle House by MVRDV
- 2 | Cat Cocoon by Warren Lieu
- 3 | Circulating Fish Tank by Sheng-Zhe Feng / Ling-Yuan Chou
- 4 | Geometric Doghouse by Ben Uyeda

# ENTRY DETAILS

## ELIGIBILITY

Entrants must be residents of New York State and qualify as "Emerging Professionals" - Students or Graduates 10 years or less removed from school at the time of the Competition Opening.

## PRIZES

First Place	\$1,000	<i>Prizes sponsored by AIA Buffalo/WNY.</i>
Second Place	\$500	
Third Place	\$250	

*Honorable Mentions will be distributed based upon merit at the discretion of the Design Jury.*

Top Prize Winners will be showcased in Press Releases, AIA Digital Newsletters (locally & state-wide), on the AIA Buffalo/WNY website, on the AIA BEP website, and other varieties of Social Media.

All entries will receive recognition on the AIA BEP website in an online gallery at the end of the competition. Select entry boards will be displayed at a Gallery Exhibition in Spring 2014 in Buffalo, NY.

## ENTRY

AIA Members	\$25	<i>All proceeds (less incidental administrative costs) will be donated to Buffalo Humane in support of their efforts to provide shelter and homes for various animals across Western New York.</i>
Non-AIA Members	\$35	
Students/Volunteers	\$20	
AIAS Members	No Fee	<i>See Entry Form for further requirements.</i>

Entry fees are non-refundable. Please make checks or money orders out to **Buffalo Architecture Foundation.**

## SCHEDULE

Competition Opens	Nov 21 2013
<b>Submissions Due</b>	<b>Mar 21 2014</b>
Jury Deliberation	Apr 2014
Winners Notified	Apr 2014
Gallery Exhibition	Spring 2014

For more information regarding the competition, entry requirements, rules, regulations, & selection criteria, please visit [aiabep.org/animalhouse](http://aiabep.org/animalhouse)

Email [info@aiabep.org](mailto:info@aiabep.org)  
Facebook [facebook.com/aiabep](https://www.facebook.com/aiabep)

# SUBMISSION REQUIREMENTS

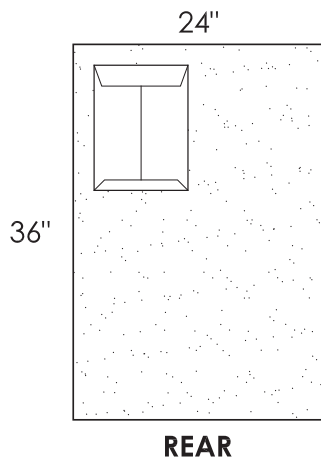
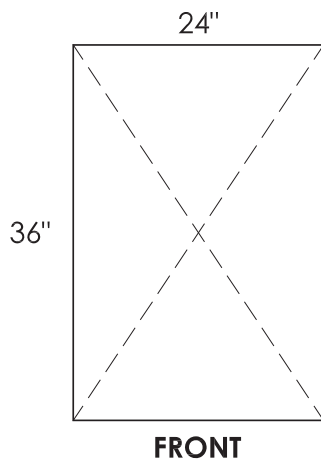

## DELIVERABLES

Each entry submission must include the following exactly in order to be considered by the jury.

### 1.) DESIGN BOARD

The primary deliverable for the competition is your Design Board. It must be 24"x36" vertically-oriented, matte-finished, and mounted to 3/16" or 1/4" foam core or equivalent. The boards must convey all intended design concepts through any drawing types the entrants choose, however, there must be at least one rendering showcasing the overall design (preferably in context with the animal it is meant for).

### 2.) PROJECT REGISTRATION PACKET

Please provide all of the following in a separate 9"x12" unmarked envelope taped to the rear of the presentation board.

#### Project Narrative

A 250 word or less description of your submission including all pertinent information related to the animal your shelter is intended for, the concept for its formal design, and additional features that may cause your project to stand out.

#### CD Containing above & Digital Images from Design Board

All entry materials must be saved digitally to an unmarked CD at 300dpi resolution (jpg or tif format only) including the Design Board and several individual images from the board itself. Please only label the files with generic names as listed below:

"Project Narrative"  
"Design Board"  
"Image 01"

#### Concealed Entry Form

The entry form must be filled out in its entirety and be included in the unmarked envelope. NOTE: This is the **ONLY** place that identification marks for entrants should be indicated on any of the materials submitted for the competition. All other materials submitted should omit all identifying marks. Numbers will be associated with submission entries upon arrival to the delivery address below.

#### Non-Refundable Entry Fee

Please make out all checks or money orders to:  
**Buffalo Architecture Foundation.**

## SUBMISSION

All deliverables shall be wrapped in brown craft paper & delivered to:

Attn: Manuel Rivera, AIA  
HHL Architects  
172 Allen St  
Buffalo, NY 14201

**\*All submissions entries MUST arrive on or before Friday March 21, 2014.**  
The submission deadline date will be strictly observed; no exceptions will be made.

Submission entries may be delivered anytime between November 21, 2013 and March 21, 2014. An email confirmation will be sent to all entrants at the close of the competition verifying their submission was received, however, it is strongly recommended that entrants use alternate package arrival verification methods to ensure proper delivery as well.

All submission entries must contain original content only and must be submitted without identifying marks, including logos, texts, insignia, or images on the display surface that could be used to identify the submission's author(s). The AIA will use all information submitted to display in exhibitions and publications to promote the competition.

# SELECTION & JURY

## SELECTION CRITERIA

All designs will be judged based on the following criteria:

**LIVABILITY** | Has the design entry met the needs and requirements of the animal for which the entry has been designed?

**CLARITY** | Does the entry have clear, concise, and appropriate design methodology and form that compliments the design intent? Aesthetic appeal of the formal design will also factor into jury deliberation.

**CONSTRUCTABILITY** | Could this house actually be built? Are the fabrication methods creatively executed in the design to reinforce the overall concepts of the shelter? Although not confirmed, the first prize winner's Animal House may be constructed dependent upon several factors including structural clarity.

**REPRESENTATION** | High-quality representation that showcases strong and captivating design identity will be sought after during jury deliberation. Whether utilizing hand-drawn or computer graphic methods, the designer's craft must be maintained at an exceptional level.

Emphasis on other considerations such as sustainability, estimated cost of construction, and animal selection are also left up to the discretion of the entrant, but will factor into the jury's evaluation of each entry.

Entrants are given wide latitude in determining the form, function, and style of their designs.

**Decisions of the Jury are Final.**

## JURY

Members of the Jury have been selected from several diverse professional & institutional organizations throughout the Western New York area to best facilitate objective judgment of the competition entries.

### Michael LaValley, Assoc. AIA, LEED® AP

Co-Founder/Co-Chair | AIA Buffalo Emerging Professionals  
Board Member | AIA Buffalo/WNY  
Project Manager/Designer | Chaintreuil Jensen Stark Architects

### Michael Anderson, AIA, LEED® AP

2014 Secretary | AIA Buffalo/WNY  
Architect | Architectural Resources

### Anne E. Dafchik, AIA, LEED® AP, NCARB

Education Coordinator | AIA Buffalo Emerging Professionals  
Architect | Kideney Architects

### Kevin M. Mahoney

2013 President | Buffalo Architecture Foundation  
Sr. Vice President/Partner | Baer & Associates

### Joyce Hwang, AIA, NCARB

Assoc. Professor/Director of Professional Studies | University at Buffalo SA&P  
Director | Ants of the Prairie

### Carol Tutzauer

President | Buffalo Humane  
Social & Behavioral Research Scientist | University at Buffalo

### Clara Miller

Vice President of Communications | Buffalo Humane  
Assist. Manager/IT Support/Campus Dining & Shops | University at Buffalo

# RULES & REGULATIONS

## **ALL ENTRANTS MUST ABIDE BY THE FOLLOWING:**

1. Entrants give AIA Buffalo/WNY and AIA BEP permission to reproduce their submission without restriction.
2. No royalties shall be payable by AIA BEP or any other sponsors for use of the submission entry materials.
3. Entrants verify that all information provided in the Concealed Entry Form is true and their submission is subject to disqualification in the event that it is found that any information has been falsified.
4. Entrants affirm that they are sole owner of the materials identified in the Animal House Competition entry, that each submitted entry is an original work, and that neither these materials nor the permission granted hereby infringes upon the ownership, copyright, trademark, or rights of others.
5. All deliverables become property of AIA Buffalo Emerging Professionals.
6. Entries shall not have been previously published in any competition publication, whether printed, online, or otherwise.
7. Entries shall not have been selected as a finalist, winner, honorable mention, etc. in any other competition.
8. If the design is submitted from a team of people, all team members must be identified on the concealed entry form.
9. All entries must be submitted without identifying marks, including logos, texts, insignia, or images on the display surface that could be used to identify the submission's author(s).
10. For jurying purposes, each design is considered as a separate entry and a separate entry fee must be paid for each. Multiple designs will not be considered as a single entry.
11. Entrants are not allowed to discuss details of their competition designs and/or entries with any of the judges directly whatsoever. Any attempt to do so will result in immediate disqualification.
12. Any deviation from competition rules may result in automatic disqualification at the discretion of the jury.



# CONCEALED ENTRY FORM

The entry form below must be filled out in its entirety and included as part of your deliverable submission. One entry form must be filled out per each entry submitted.

- By checking this box, I/we hereby comply with all of the rules, regulations, guidelines and requirements as outlined in the Official Competition Brief.

## CONTACT INFORMATION (FILL OUT AS APPLICABLE)

NAME .....

EMAIL .....

PHONE .....

OTHER TEAM MEMBERS

.....  
.....  
.....

## ELIGIBILITY INFORMATION (CHECK ONE)

- I am:
- An American Institute of Architects Member (\$25)
  - A Non-AIA Member (\$35)
  - A Student (\$20)
  - An Active Volunteer (\$20)
    - AIA BEP
    - AIA Buffalo/WNY or AIA NYS Chapter
    - Buffalo Architecture Foundation
  - An AIAS Member (No Fee)

## SUPPLEMENTARY ELIGIBILITY INFORMATION (FILL OUT AS APPLICABLE)

### AIA/AIAS MEMBER

MEMBER # .....

### ACTIVE VOLUNTEER (PROVIDE REFERENCE TO VERIFY YOUR PARTICIPATION)

NAME .....

EMAIL .....

### STUDENT (PROVIDE PHOTOCOPY OF SCHOOL PHOTO ID WITH ENTRY FORM)

SCHOOL .....

### FOR COMMITTEE USE ONLY

- This entry complies with all aforementioned rule, submission, and eligibility requirements.



**OFFICIAL COMPETITION BRIEF**

[www.aiabep.org/animalhouse](http://www.aiabep.org/animalhouse)



**AIABEP**  
Buffalo Emerging Professionals

